

# Data Sheet

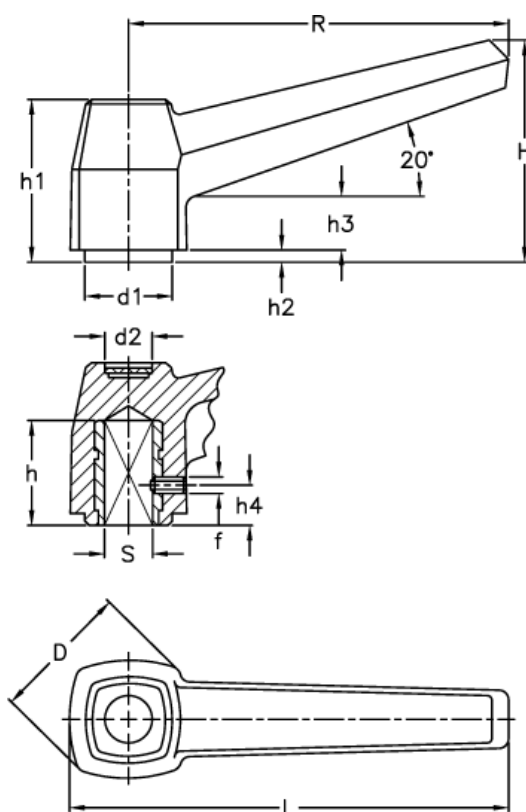

Article number: 2303039011  
Description: E+G Lever handle  
MF.40 N-5x5

## Measures



D = 18	h3 = 9
d1 = 11.5	h4 = 7
d2 = 9	L = 50
f = M4	R = 42
h = 15	S H9 = 5x5
H = 27	
h1 = 22	
h2 = 1.8	